

Turbine Meter

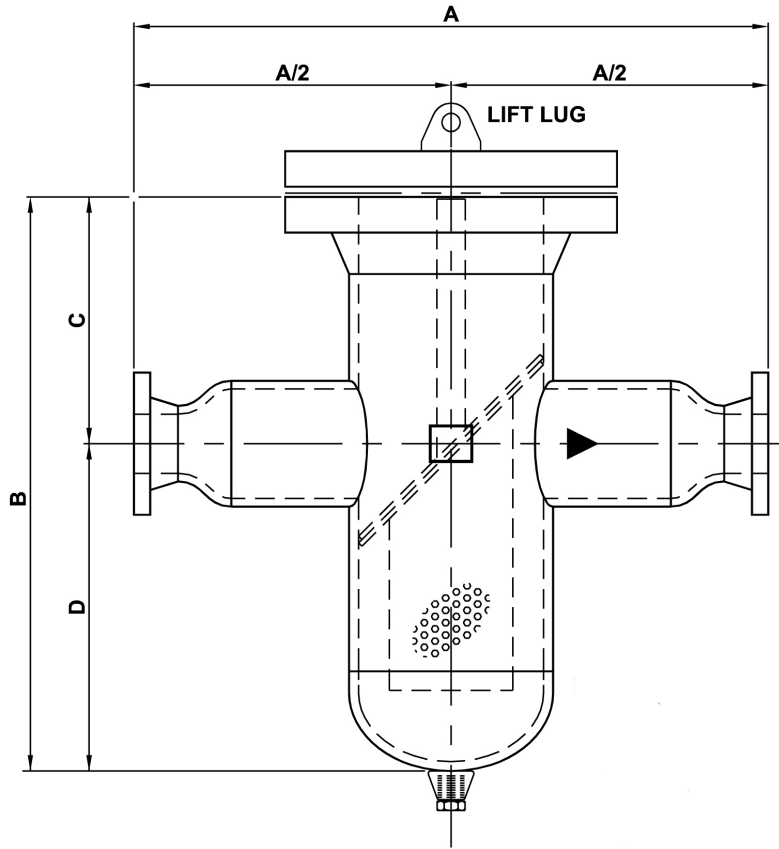

Dimensional Data

Nozzle Size (NPS)	Vessel Size (NPS)	A	B	C	D	Open Area	Drain Size	Weights (lbs)		
								Class 150	Class 300	Class 600
3"/6"	10"	36"	31"	13"	18"	1670%	0.75"	264	320	452
4"/8"	12"	40"	36"	15"	21"	1547%	1.00"	353	431	515
6"/10"	16"	46"	42"	18"	24"	994%	1.00"	664	978	1555
8"/12"	18"	51"	49"	20"	29"	935%	1.00"	1057	1454	2185
10"/14"	20"	65"	51"	22"	29"	592%	2.00"	1382	1816	2183
12"/18"	24"	71"	67"	24"	43"	867%	2.00"	2193	2430	4383